



COMMERCIAL FANS
VENTILOR





COMMERCIAL FANS VENTILOR

- Axial fans to extract air and fumes directly outside.
- For installation in windows, double glazing and panels up to 50 mm.
- Rain proof external grille.
- In accordance with EN 60335-2-80.
- In shining ABS material.
- **Ventilor 20/8 M** - Manual immediate opening and closing of shutter through a pull cord.
- **Ventilor 20/8 AR - 25/10 AR**
- Automatic and silent opening and closing of shutter.
- Warning operating light.

Dimensions

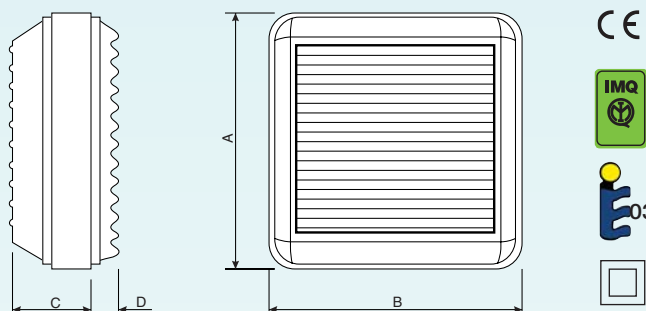

Model	A	B	C	D
Ventilor 20/8 M - 20/8 AR	280	280	94	30
Ventilor 25/10 AR	335	335	128	33

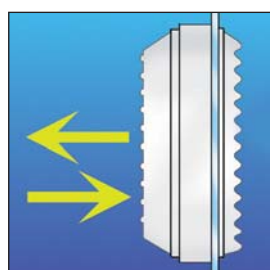

Air-flow reversibility extract and intake for models 20/8 AR and 25/10 AR.

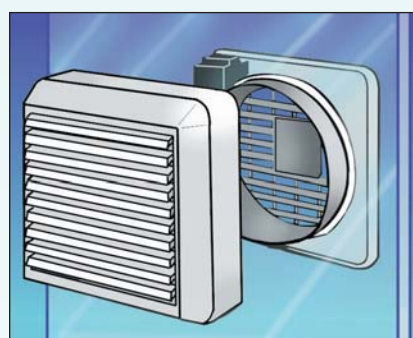

Quick and simple installation and maintenance by locking ring which gives some tolerance on the hole size in the glass.

- **Double glazing kit for Ventilor 20/8 and 25/10**, accessory for installation in double glazing, includes locking ring and spigot.

- **Wall fixing kit for Ventilor**
Hole diameter 250 mm (20/8) and 300 mm (25/10).

Model	Ref.
Double glazing kit Ventilor 20/8	OW 804 7
Double glazing kit Ventilor 25/10	OW 805 4
Built in kit for speed controller	OW 905 2
Wall fixing kit Ventilor	OW 191 9
RG 5 AR	OW 315 4
Kit for Radio Transmission	OW 913 6



Kit for Radio Transmission.



RG 5 AR

Technical Data

Model	Ref.	Hole diameter mm	Flow rate m ³ /h	W	Nominal Voltage and Frequency	dB (A) 3 m	Weight kg
VENTILOR 20/8 M	OW 188 5	225÷235	450	50	220-240V 50/60Hz	58	2,4
VENTILOR 20/8 AR	OW 190 1	225÷235	450	50	220-240V 50/60Hz	58	2,4
VENTILOR 25/10 AR	OW 192 7	275÷285	750	60	220-240V 50/60Hz	59	5,6