



CENTRIFUGAL CHIMNEY FAN  
**TURBOCAMINO** FOR HOT FUMES





# CENTRIFUGAL CHIMNEY FAN TURBOCAMINO FOR HOT FUMES

- Centrifugal chimney fan to extract hot dusty fumes.
- Suitable for use on fireplaces, oven waste or industrial hoods.
- Designed to extract smoke at temperature up to 200° C.
- For all chimneys with insufficient up-draught.
- Induction motor on ball bearings, IP 54 protection, class F insulation and fitted with cooling impeller.
- Aluminium cover protects the product from atmospheric conditions.
- Zinc plated steel impeller statically and dynamically balanced.
- Safety protection grille.
- In accordance with the essential requirements of 89/392/CE directive concerning machines, and with European Standards UNI 10615, UNI EN 292-1 e 2, UNI EN 294, CEI EN 60204-1.
- With fixing steel frame.
- Electronic regulator RGE OW3170 included.
- Industrial regulator available (see page 88).

## Dimensions

CE

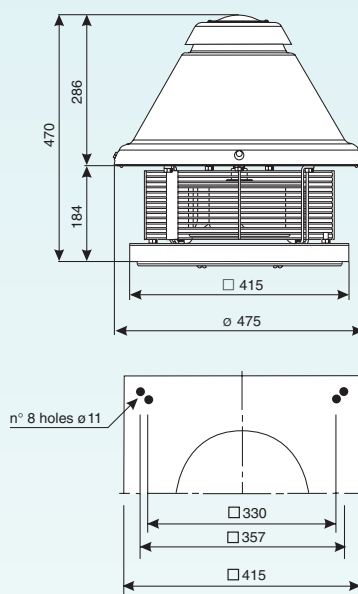

ø hole from 175 mm adjustable up to 225 mm.

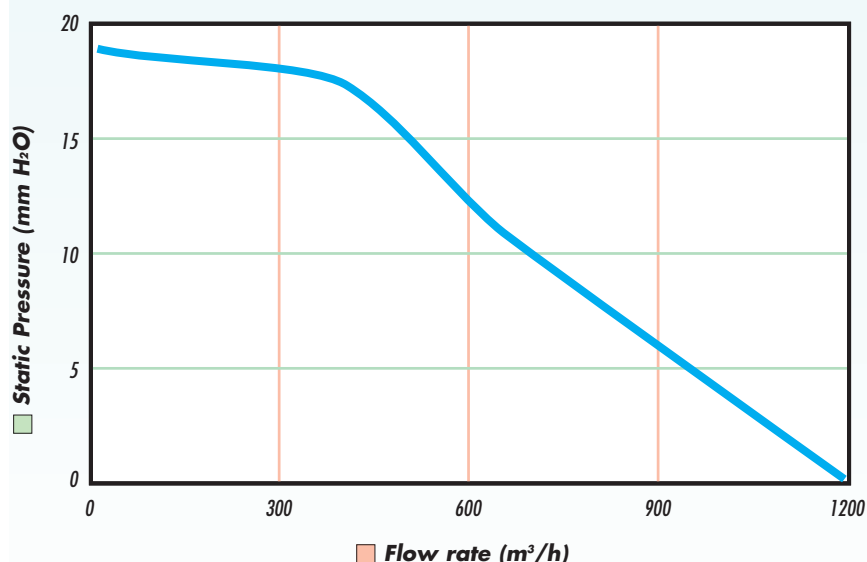

## Technical Data

Model	Ref.	Motor Protection	Motor single-phase	Flow rate m <sup>3</sup> /h	Max Press. mm. H <sub>2</sub> O	N. Poles	W	Hz	Nom. curr. in A at 230V	dB (A) 2 m	RPM	Weight Kg
<b>TURBOCAMINO</b>	OW 554 8	IP54	220-240	1200	19,5	4	110	50/60	0,6	52,5	1400	15